

POWER DISTRIBUTION		
COMPUTERIZED ELEVATOR CONTROL CORP. 636 11TH AVENUE NEW YORK, NEW YORK 10036 TEL (212) 397-0606	DATE 1-23-1989	NOTES 1. NO GFCI
BUILDING: TEXAS AMERICAN BANK		
LOCATION: AMARILLO TX		
CONTRACTOR: ELEVATOR TECHNOLOGY		
CAR NO. 1-0	DATE: 1-23-89	
DRAWING NO. MG452-28	JOB NO. 130	

h

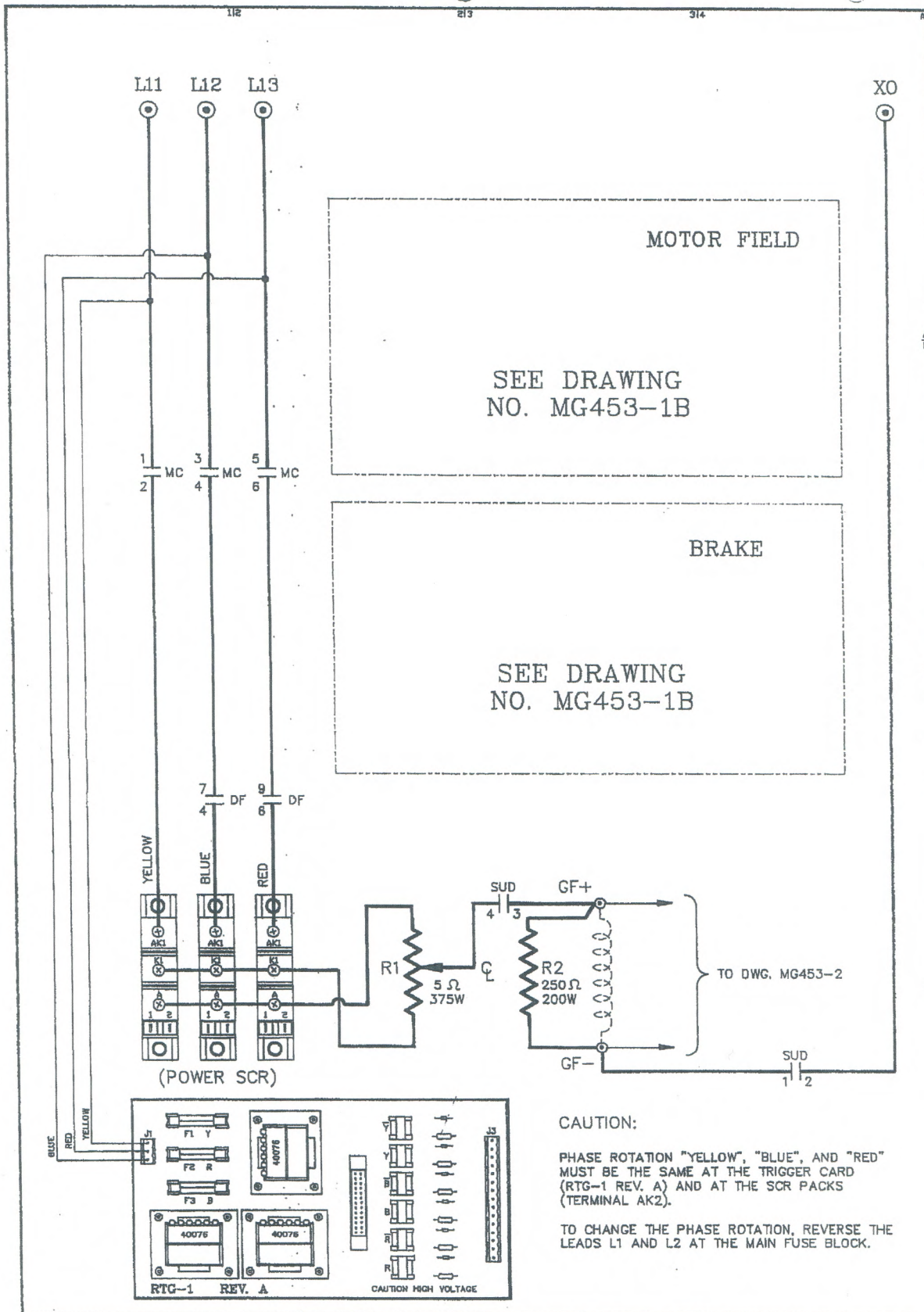

POWER CONTROL

COMPUTERIZED ELEVATOR CONTROL CORP. 636 11TH AVENUE NEW YORK, NEW YORK 10036 TEL. (212) 397-0606	DATE	NOTES
BUILDING: HAS AMERICAN BANK		
LOCATION: AMADILLO TV		
CONTRACTOR: ELEVATOR TECHNOLOGY		
CAR NO. 1-4	DATE: 11-29-81	
DRAWING NO. MG453-1A	JOB NO. 1730	

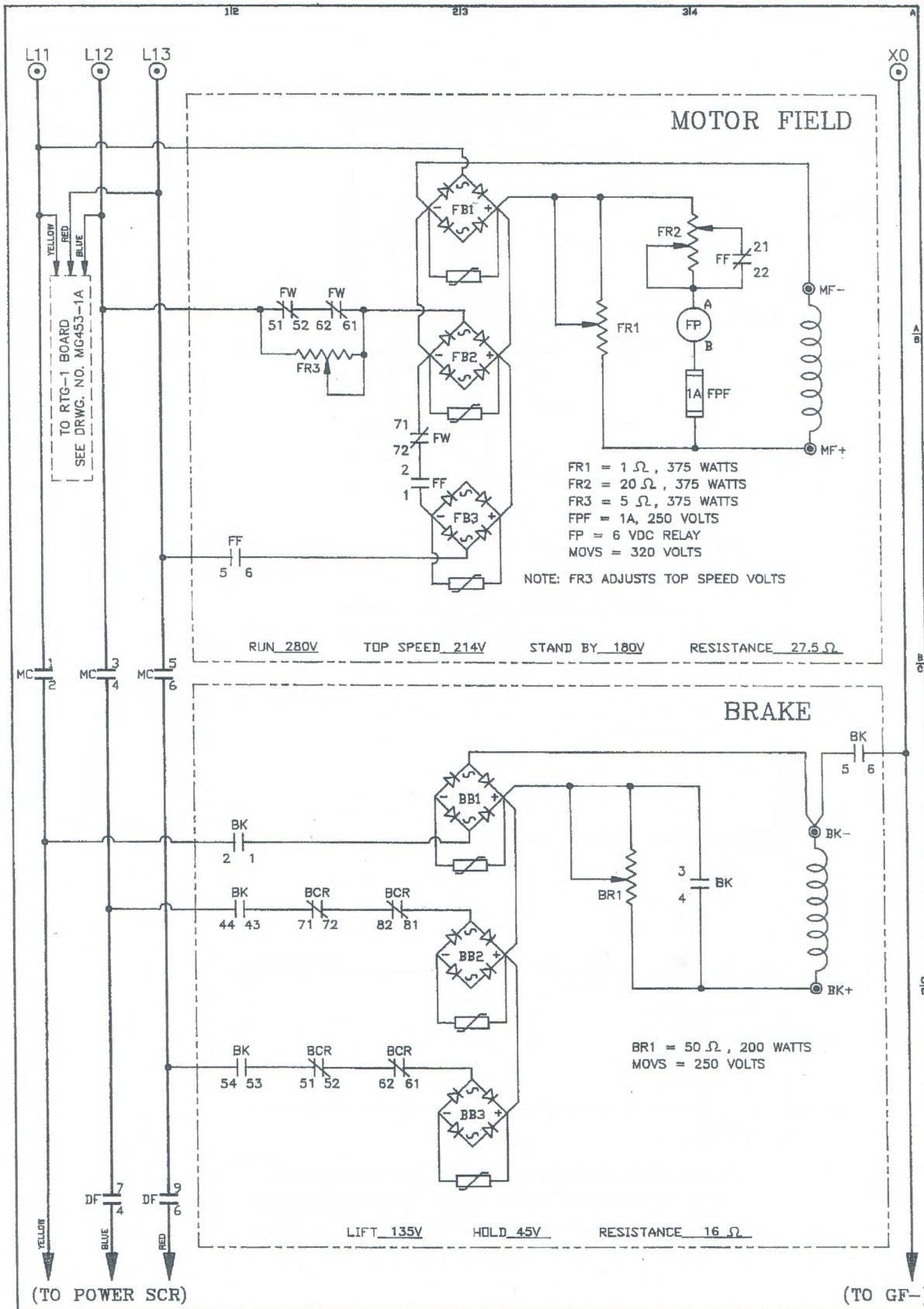

POWER CONTROL

COMPUTERIZED ELEVATOR CONTROL CORP.		DATE	RECORD CHANGES
636 11TH AVENUE NEW YORK, NEW YORK 10036 TEL. (212) 397-0606			REF. 001198
BUILDING: TEXAS AMERICAN BANK			
LOCATION: AMARILLO, TX.			
CONTRACTOR: ELEVATOR TECHNOLOGY INC.			
CAR NO. 1,2,3,4	DATE: 11-21-1989		
DRAWING NO. MG453-1B	JOB NO. 1730		

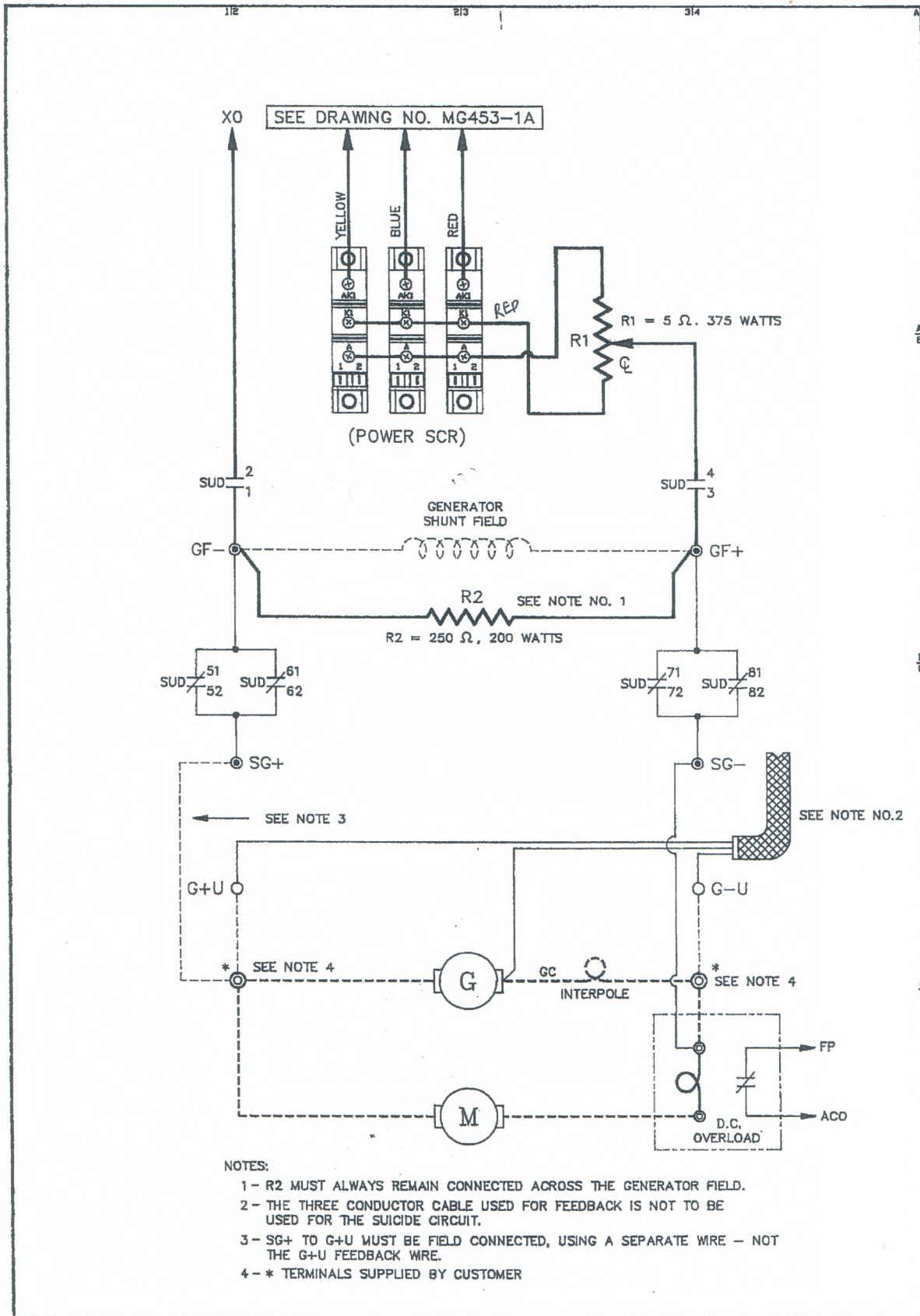

GENERATOR FIELD "SUICIDE" CIRCUIT

COMPUTERIZED ELEVATOR CONTROL CORP.	DATE	RECORD CHANGES
836 11TH AVENUE NEW YORK, NEW YORK 10036 TEL. (212) 397-0606	2-16-1989	REVISED
BUILDING: TEXAS AMERICAN BANK		
LOCATION: ANAHEIM, TX		
CONTRACTOR: ELEVATOR TECHNOLOGY		
CAR NO. 1-4	DATE: 11-27-87	
DRAWING NO. MG453-2	JOB NO. 1130	

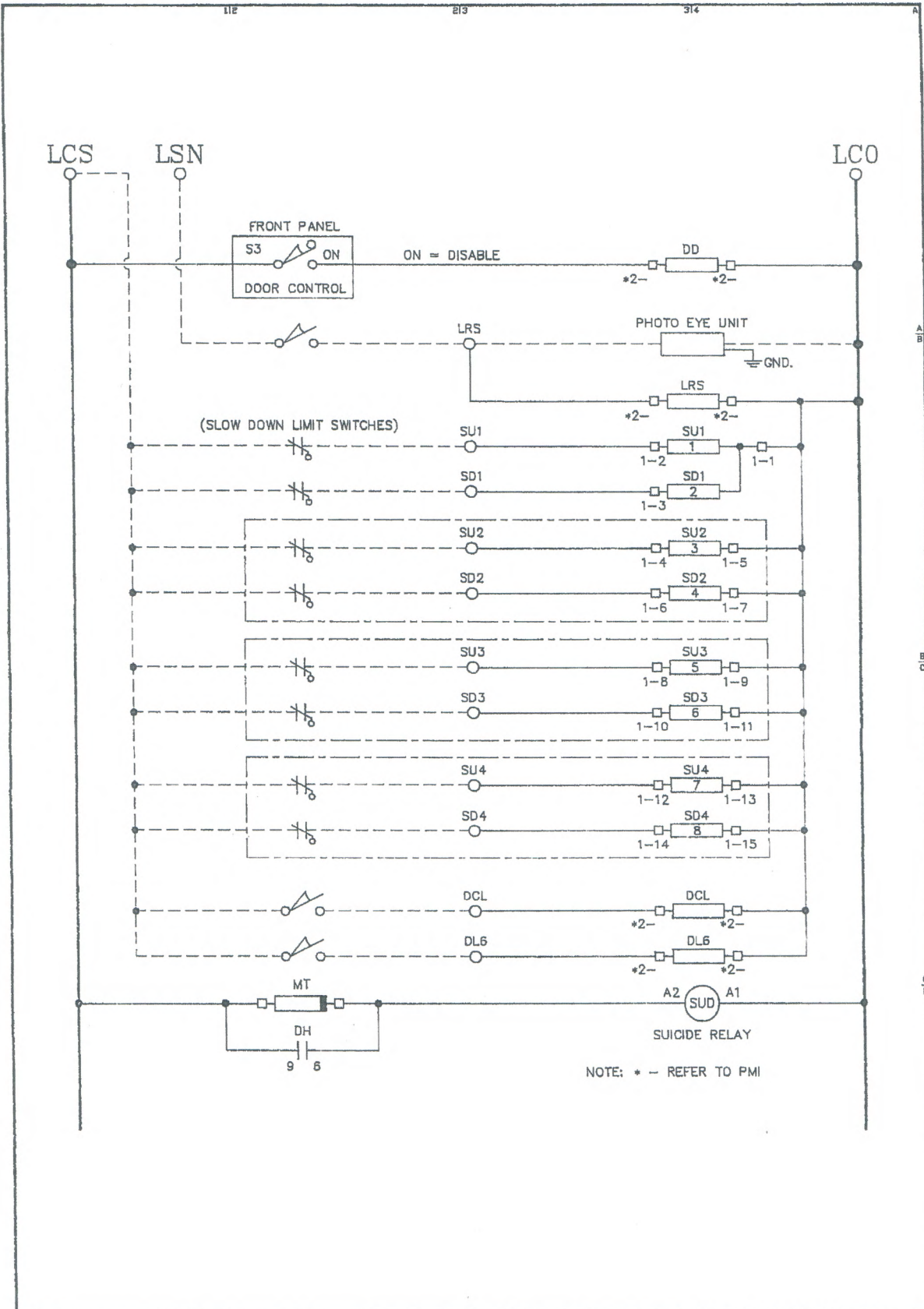

RELAY SECTION 1

COMPUTERIZED ELEVATOR CONTROL CORP.	DATE	NOTES
636 11TH AVENUE NEW YORK, NEW YORK 10036 TEL. (212) 397-0606		1. 4 LIMITS
BUILDING: TEXAS AMERICAN BANK		
LOCATION: AVALIUD, TX		
CONTRACTOR: ELEVATOR TECHNOLOGY		
CAR NO. 1-4	DATE: 11-29-81	
DRAWING NO. R5101-2	JOB NO. 1730	

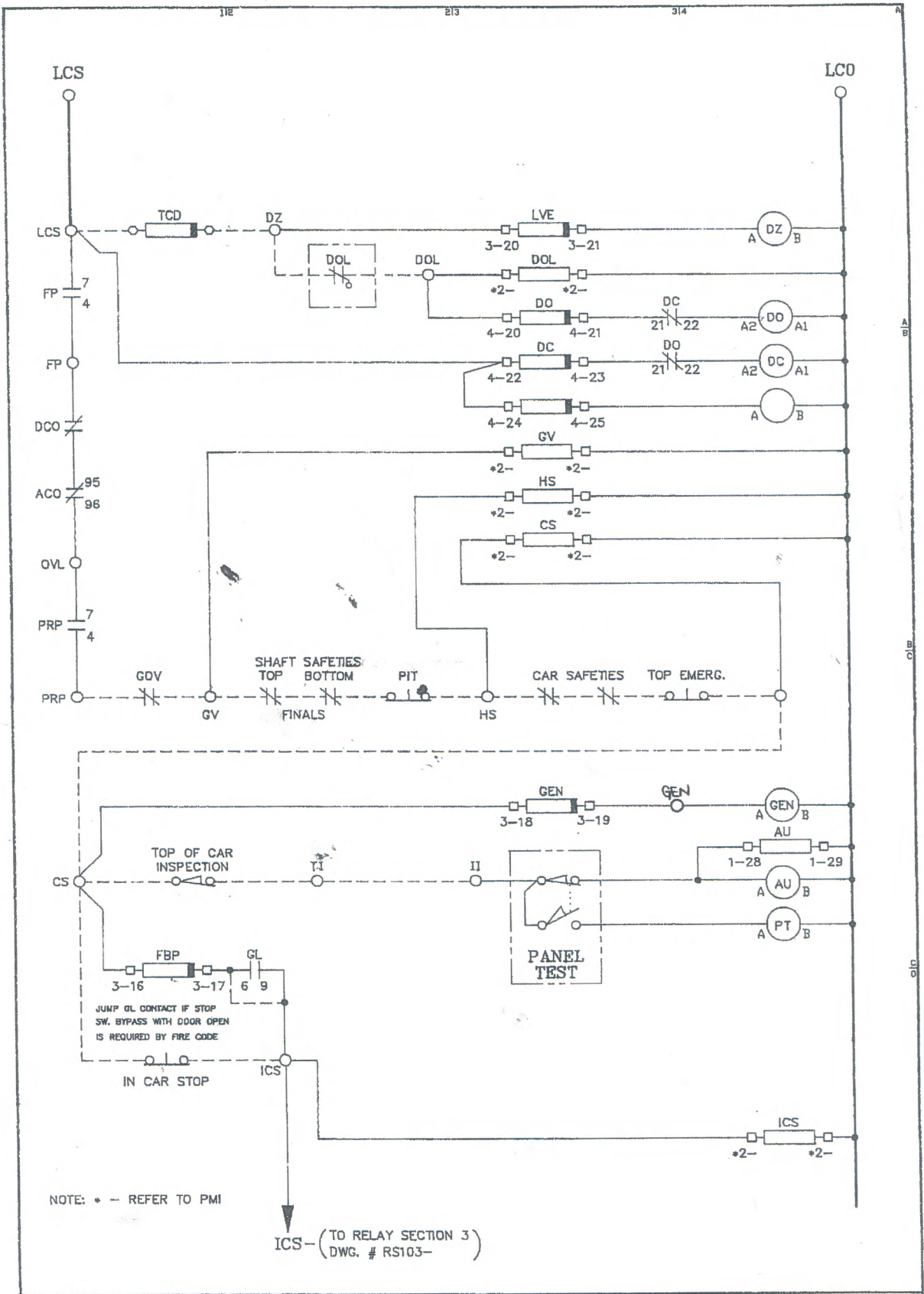

RELAY SECTION 2

COMPUTERIZED ELEVATOR CONTROL CORP.		DATE	RECORD CHANGES
636 11TH AVENUE NEW YORK, NEW YORK 10036 TEL. (212) 397-0606			
BUILDING: <u>TEXAS AMERICAN BANK</u>			1. USE FOR DOUER JOBS
LOCATION: <u>QUAD 10, TX</u>			2. WITHOUT IN CAR ACCESS
CONTRACTOR: <u>ELEVATOR TECHNOLOGY</u>			3. WITHOUT REAR DOOR OPERATOR
CAR NO. <u>1-1</u>	DATE: <u>11-29-87</u>		
DRAWING NO. RS102-17	JOB NO. <u>1730</u>		

UR

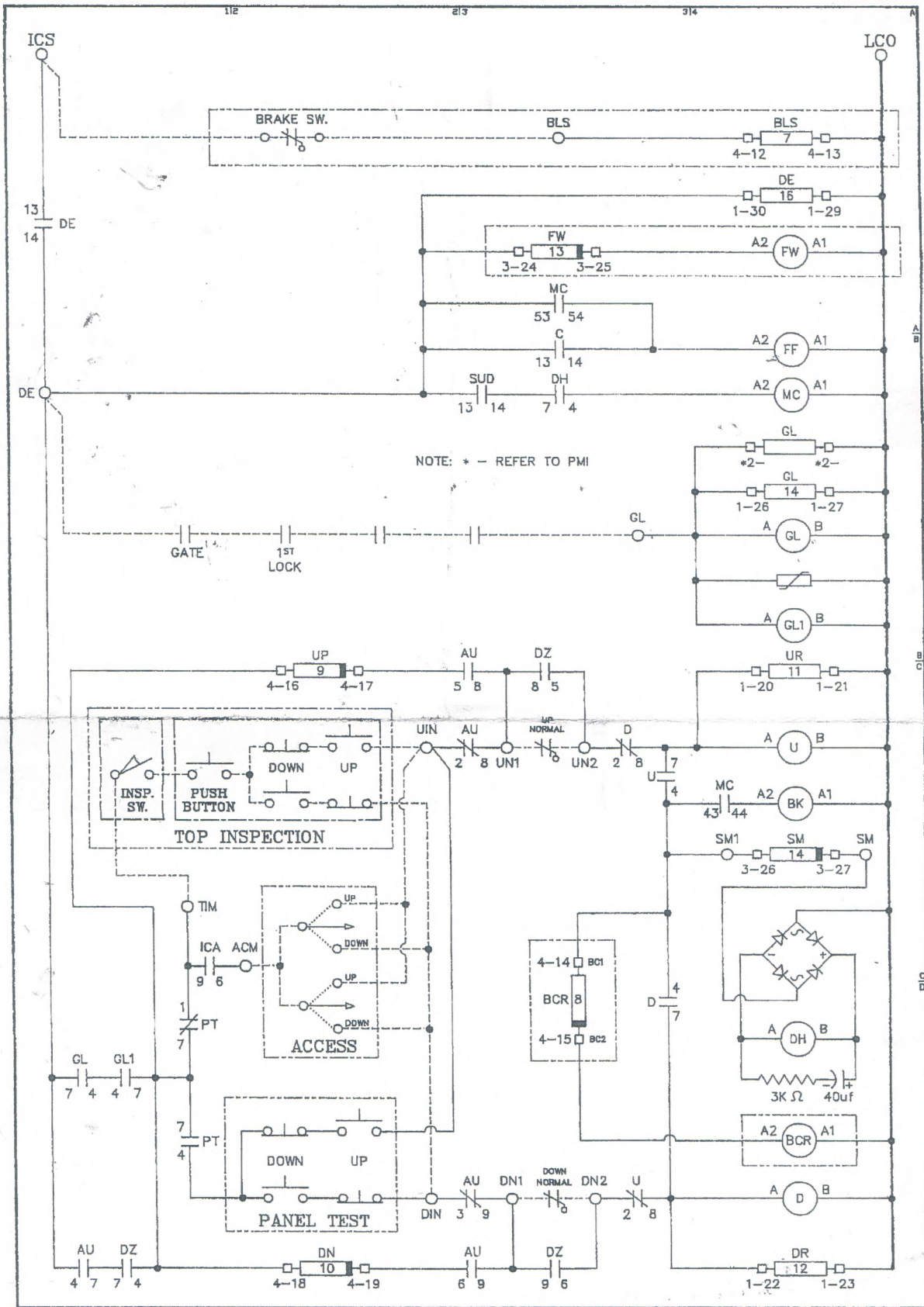

RELAY SECTION 3

COMPUTERIZED ELEVATOR CONTROL CORP.		DATE	NOTES
636 11TH AVENUE NEW YORK, NEW YORK 10036 TEL. (212) 397-0606			1. WITHOUT REAR
BUILDING: <u>TEXAS AMERICAN BANK</u>			2. WITHOUT ETS
LOCATION: <u>AMERILLO, TX</u>			3. WITH IN CAR ACCESS
CONTRACTOR: <u>ELEVATOR TECHNOLOGY</u>			
CAR NO. <u>1-9</u>	DATE: <u>11-27-89</u>		
DRAWING NO. <u>RS103-17</u>	JOB NO. <u>1730</u>		

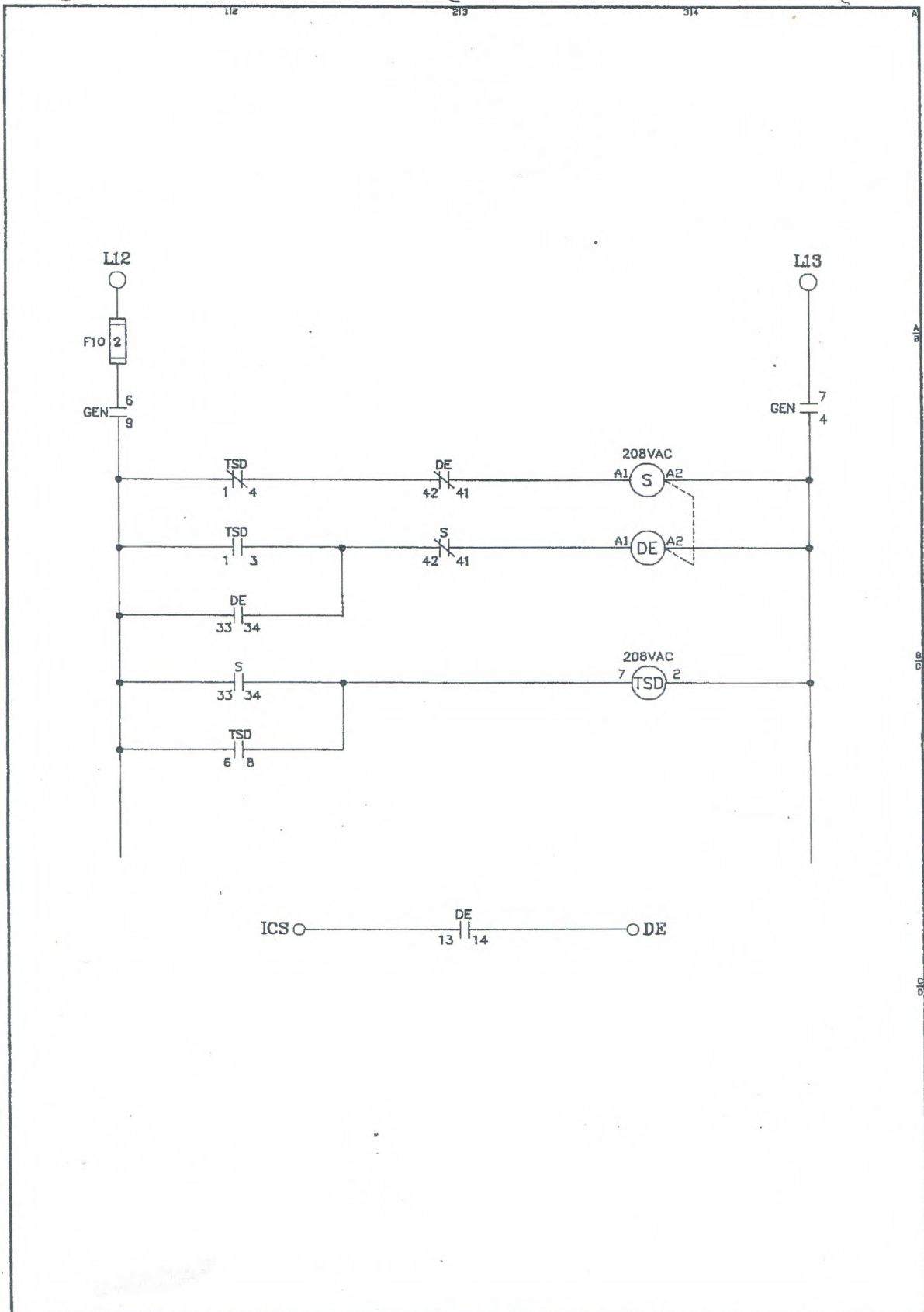

RELAY SECTION 4

COMPUTERIZED ELEVATOR CONTROL CORP.	DATE	NOTES
636 11TH AVENUE NEW YORK, NEW YORK 10036 TEL. (212) 397-0606	1-23-1989	FOR S&S CONTACTOR 25HP & 40HP
BUILDING: TEXAS AMERICAN BANK		
LOCATION: AVAZILLO, TX		
CONTRACTOR: ELEVATOR TECHNOLOGY		
CAR NO. 1-4	DATE: 11-27-89	
DRAWING NO. RS104-1	JOB NO. 1730	

63

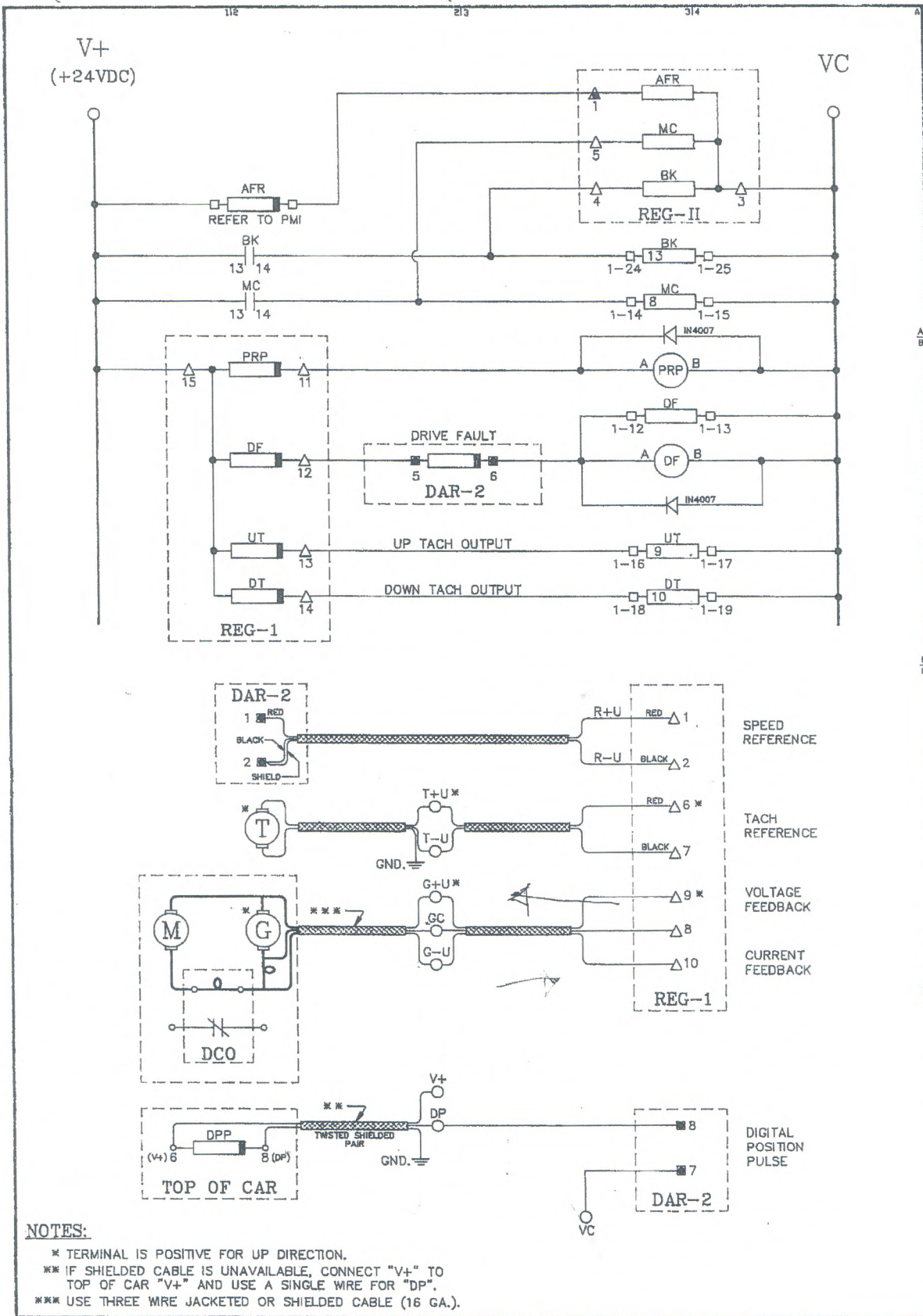

NOTES:

- * TERMINAL IS POSITIVE FOR UP DIRECTION.
- ** IF SHIELDED CABLE IS UNAVAILABLE, CONNECT "V+" TO TOP OF CAR "V+" AND USE A SINGLE WIRE FOR "DP".
- *** USE THREE WIRE JACKETED OR SHIELDED CABLE (16 GA.).

DRIVE LOGIC INTERFACE

COMPUTERIZED ELEVATOR CONTROL CORP.	DATE	NOTES
636 11TH AVENUE NEW YORK, NEW YORK 10036 TEL. (212) 397-0606		
BUILDING: <u>TEXAS AMERICAN BANK</u>		
LOCATION: <u>AMARILLO, TX</u>		
CONTRACTOR: <u>ELEVATOR TECHNOLOGY</u>		
CAR NO. <u>1-4</u>	DATE: <u>11-27-87</u>	
DRAWING NO. <u>MG458-1A</u>	JOB NO. <u>1750</u>	

VOLTAGE: 48 VDC

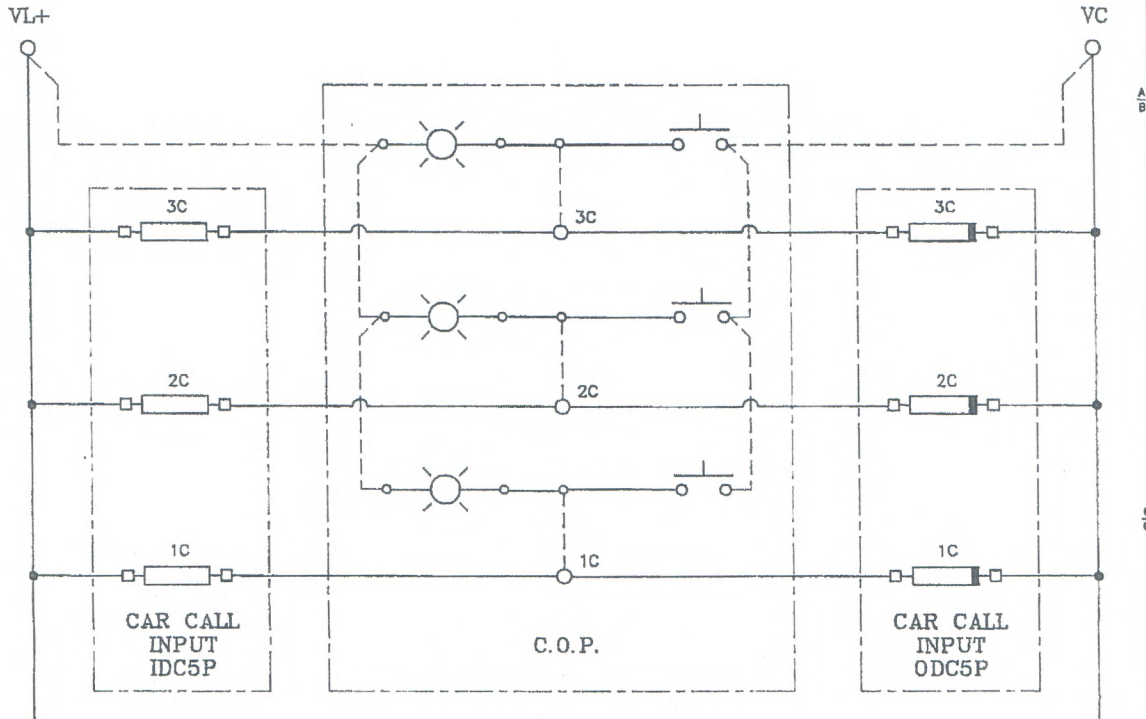

PMI INTERFACE SECTION 1

COMPUTERIZED ELEVATOR CONTROL CORP. 636 11TH AVENUE NEW YORK, NEW YORK 10036 TEL (212) 397-0606	DATE	NOTES
BUILDING: TEXAS AMERICAN BANK		
LOCATION: ADRIANO TX		
CONTRACTOR: ELEVATOR TECHNOLOGY		
CAR NO. 1-4	DATE: 11-01-87	
DRAWING NO. WS504-4	JOB NO. 1730	

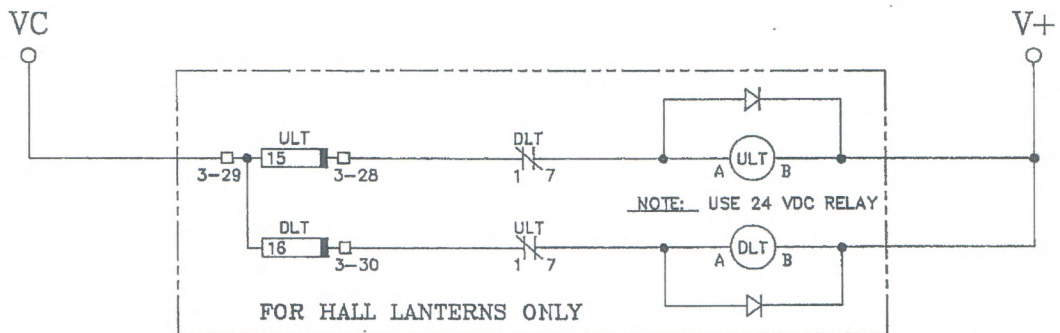
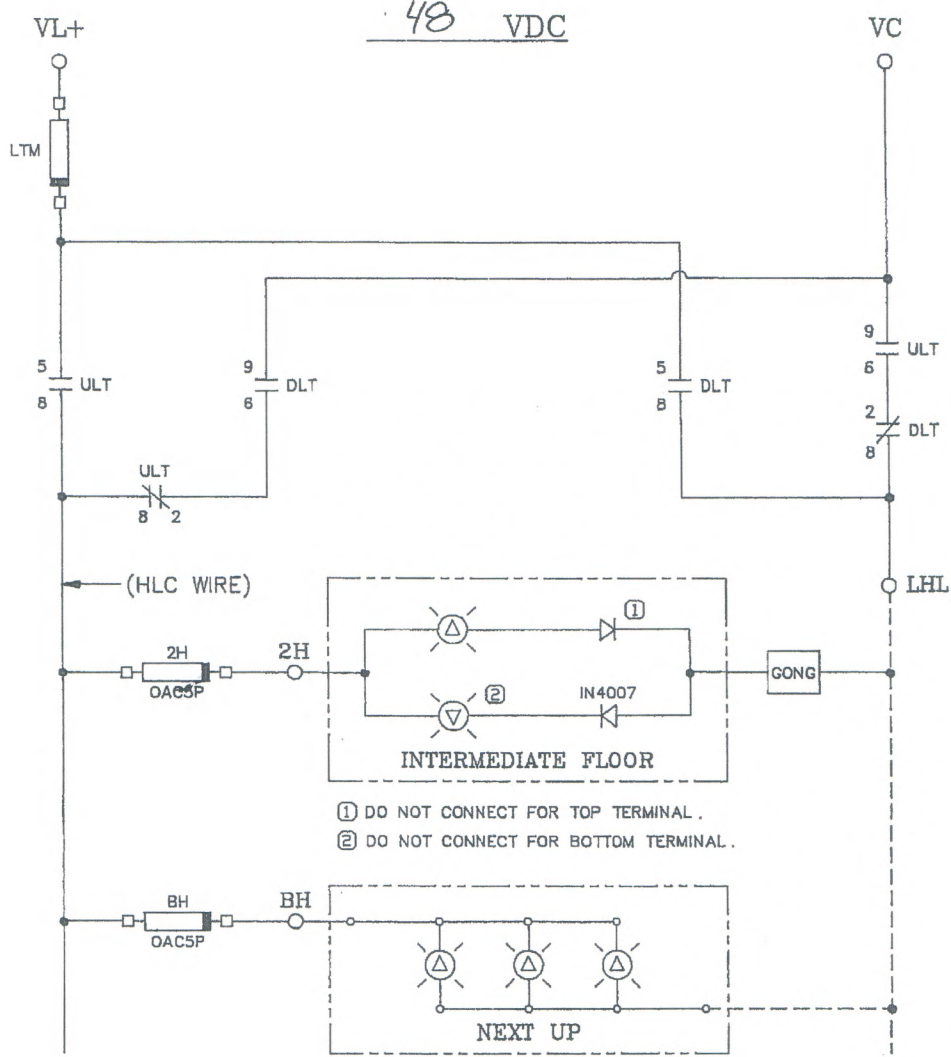

48 VOLTS DC HALL LANTERN CIRCUIT

COMPUTERIZED ELEVATOR CONTROL CORP.		DATE	NOTES
636 11TH AVENUE NEW YORK, NEW YORK 10036 TEL. (212) 397-0606			
BUILDING: TEXAS AMERICAN BANK			
LOCATION: AMARILLO, TX			
CONTRACTOR: ELEVATOR TECHNOLOGY			
CAR NO. 1-4	DATE: 11-27-87		
DRAWING NO. MS501-1A	JOB NO. 1730		

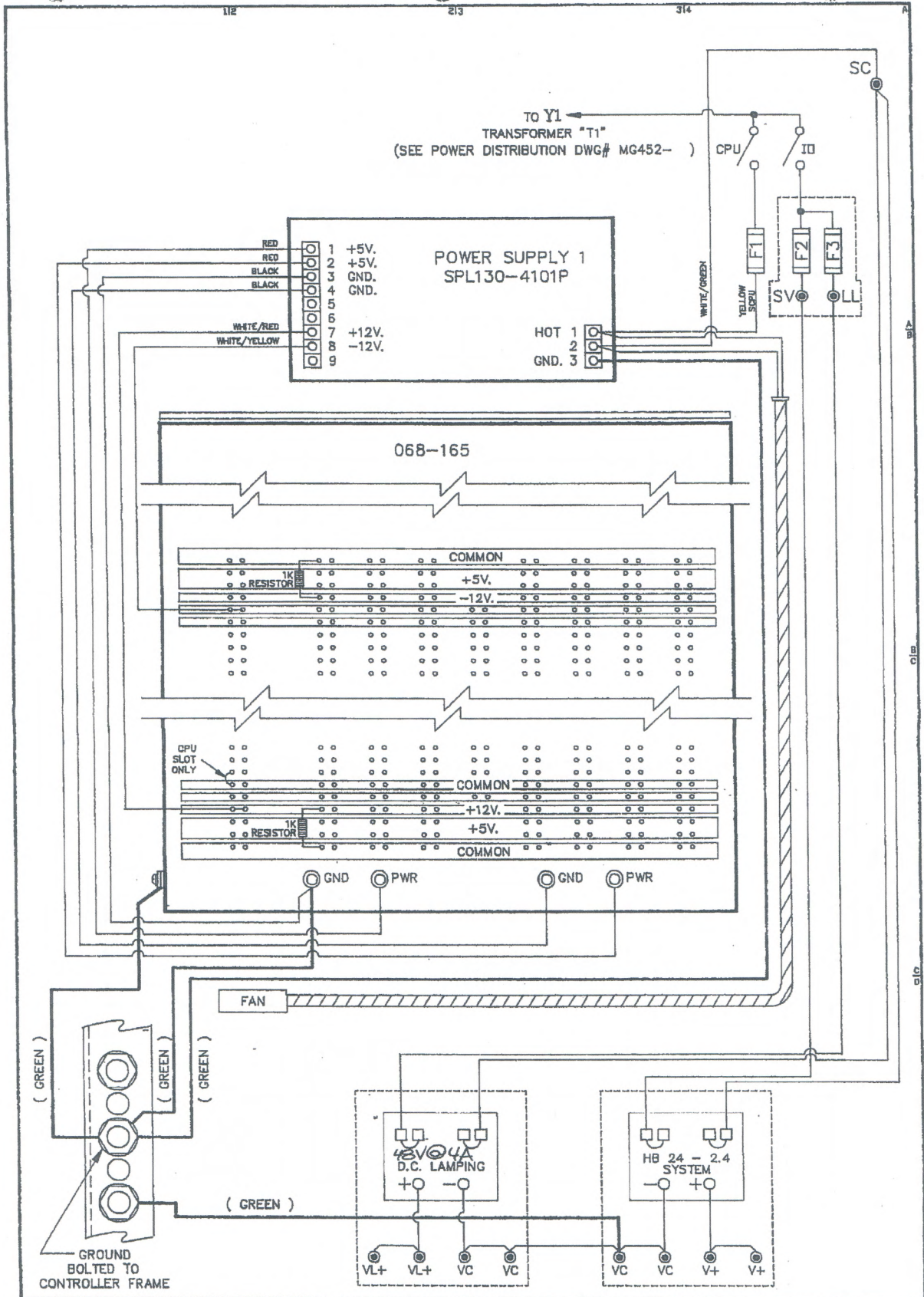

LOW VOLTAGE POWER SUPPLY

COMPUTERIZED ELEVATOR CONTROL CORP.		DATE	NOTES
636 11TH AVENUE NEW YORK, NEW YORK 10036 TEL. (212) 397-0606			1. FOR DC LAMPING
BUILDING: TEXAS AMERICAN BANK			2. NO GFCI
LOCATION: AMARILLO, TX			
CONTRACTOR: ELEVATOR TECHNOLOGY			
CAR NO. 1-9	DATE: 11-27-87		
DRAWING NO. MS510-1	JOB NO. 730		

VOLTAGE: 48 VDC

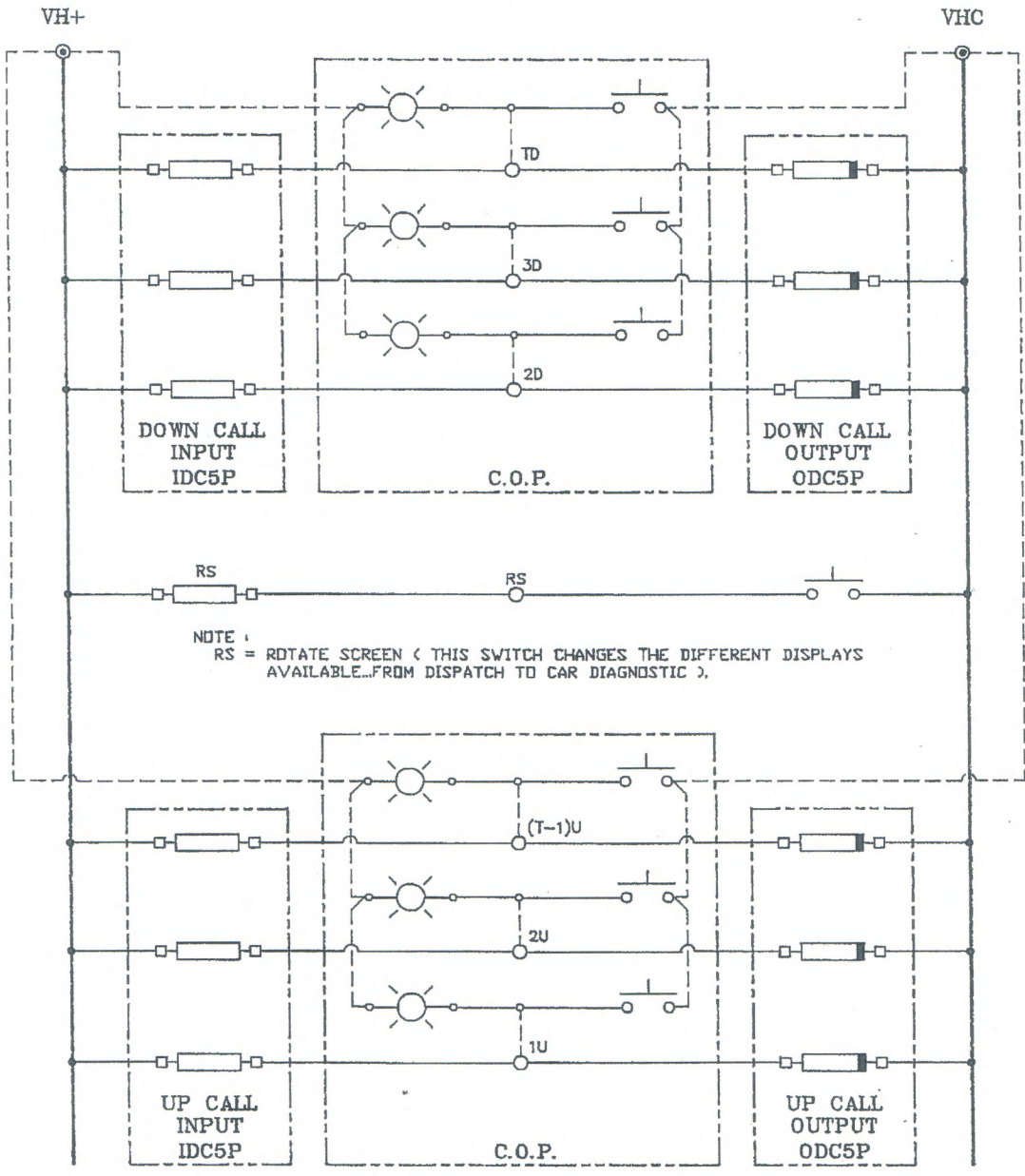

NOTE:
 RS = ROTATE SCREEN (THIS SWITCH CHANGES THE DIFFERENT DISPLAYS AVAILABLE...FROM DISPATCH TO CAR DIAGNOSTIC).

"GROUP" PMI INTERFACE HALL CALLS

COMPUTERIZED ELEVATOR CONTROL CORP.		DATE	NOTES
638 11TH AVENUE NEW YORK, NEW YORK 10036 TEL. (212) 397-0606			USE WITH 24 VDC
BUILDING: <u>TEXAS AMERICAN BANK</u>			
LOCATION: <u>AMARILLO, TX</u>			
CONTRACTOR: <u>LEASER TECHNOLOGY</u>			
CAR NO. <u>1-9</u>	DATE: <u>11-27-87</u>		
DRAWING NO. <u>GC704-1</u>	JOB NO. <u>173</u>		

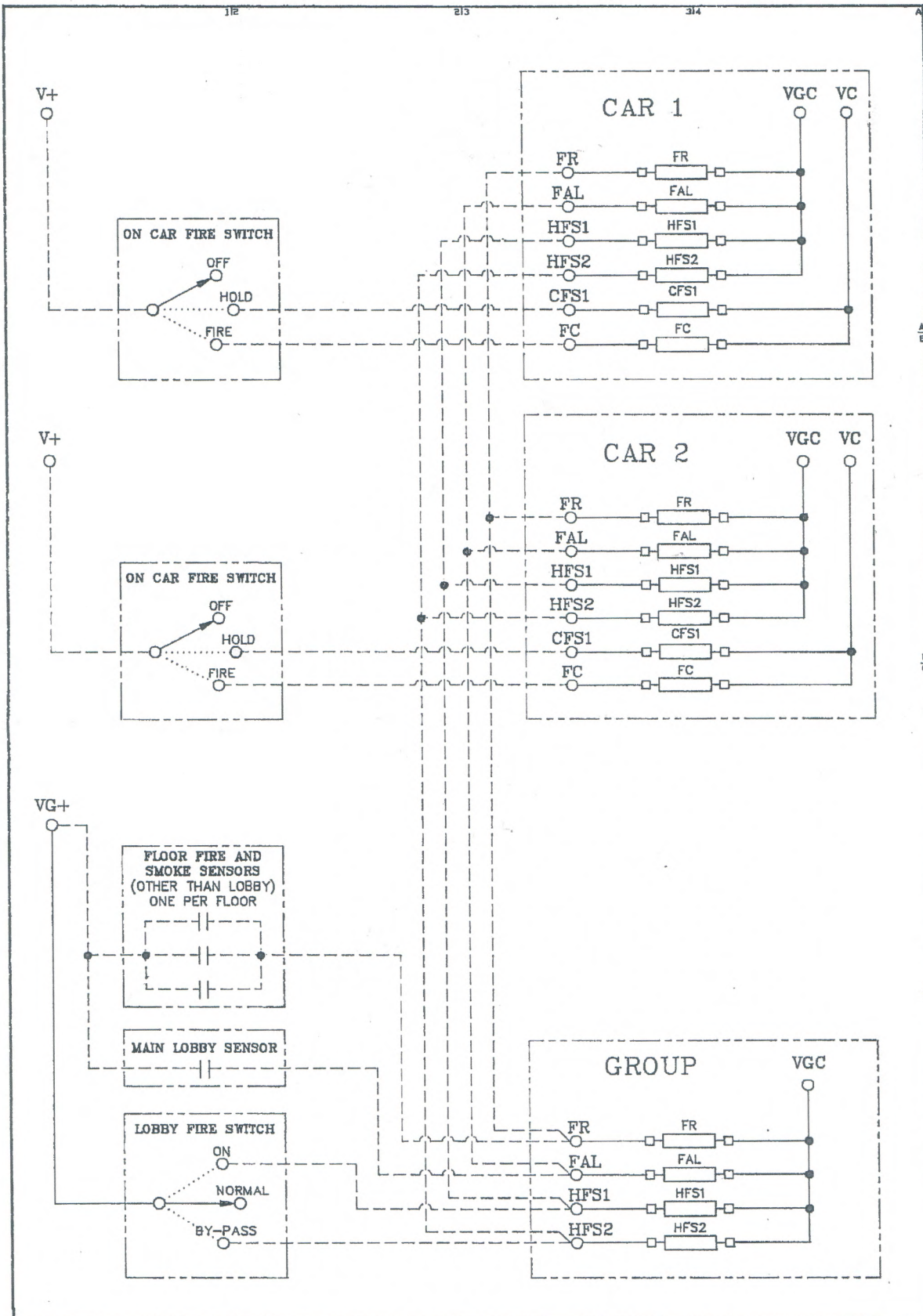

FIRE CONTROL ANSI - 1985

COMPUTERIZED ELEVATOR CONTROL CORP.		DATE	RECORD CHANGES
636 11TH AVENUE NEW YORK, NEW YORK 10036 TEL. (212) 397-0606			
BUILDING: TEXAS AMERICAN BANK			
LOCATION: AMARILLO, TX.			
CONTRACTOR: ELEVATOR TECHNOLOGY			
CAR NO. 1-4	DATE: 11-29-89		
DRAWING NO. MS506-1	JOB NO. 1730		

NOTES:

- 1 - WIRED FOR 115 VOLTS A.C.
- 2 - SEPARATE 115 VOLTS A.C. AT 15 AMP POWER SOURCE IS REQUIRED TO FEED THE GROUP CONTROLLER

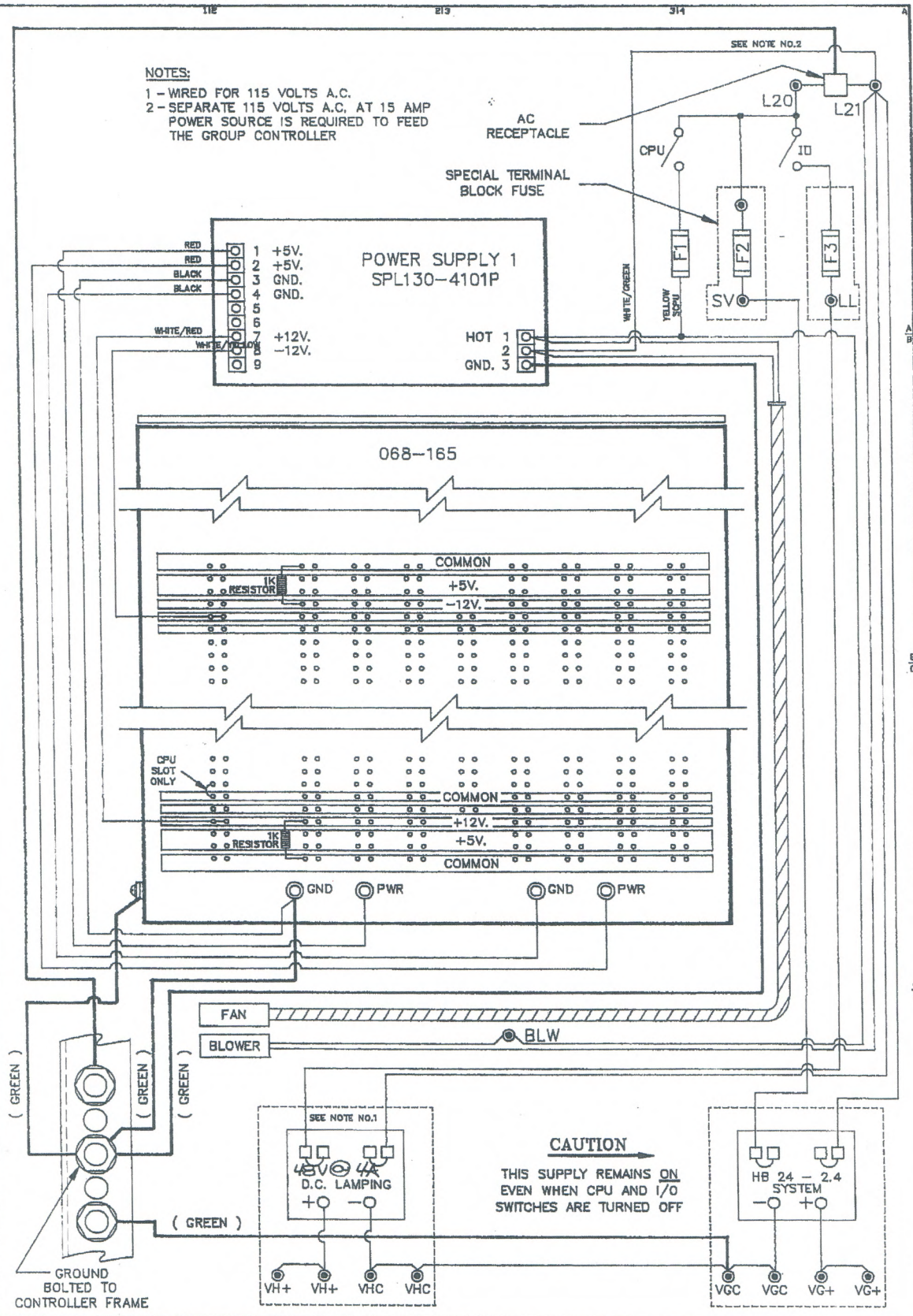

"GROUP" LOW VOLTAGE POWER SUPPLY

COMPUTERIZED ELEVATOR CONTROL CORP.	DATE	NOTES
636 11TH AVENUE NEW YORK, NEW YORK 10036 TEL. (212) 397-0806		FOR DC LAMPING
BUILDING: TEXAS AMERICAN BANK		
LOCATION: SPARILL, TX		
CONTRACTOR: ELEVATOR TECHNOLOGY		
CAR NO. 1-9	DATE: 11-29-89	
DRAWING NO. GC710-1	JOB NO. 130	

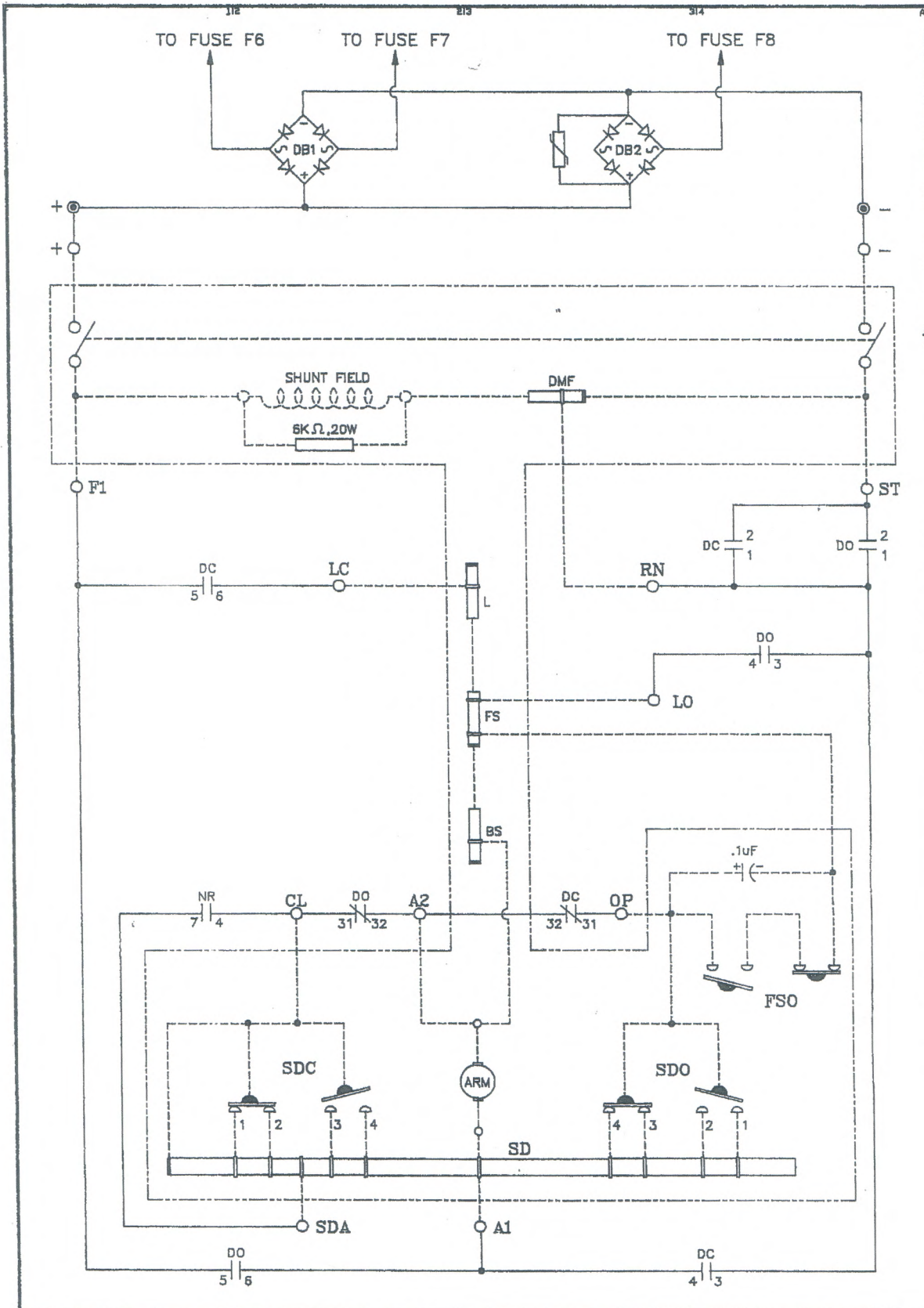

FRONT MOM/MOH GAL DOOR OPERATOR

COMPUTERIZED ELEVATOR CONTROL CORP.		DATE	RECORD CHANGES
636 11TH AVENUE NEW YORK, NEW YORK 10036 TEL. (212) 397-0808		10-16-1989	REVISED
BUILDING: TEXAS AMERICAN BANK			
LOCATION: AMARILLO TX			
CONTRACTOR: ELEVATOR TECHNOLOGY			
CAR NO. 1-4	DATE: 11-27-89		
DRAWING NO. DO117-1	JOB NO. F30		

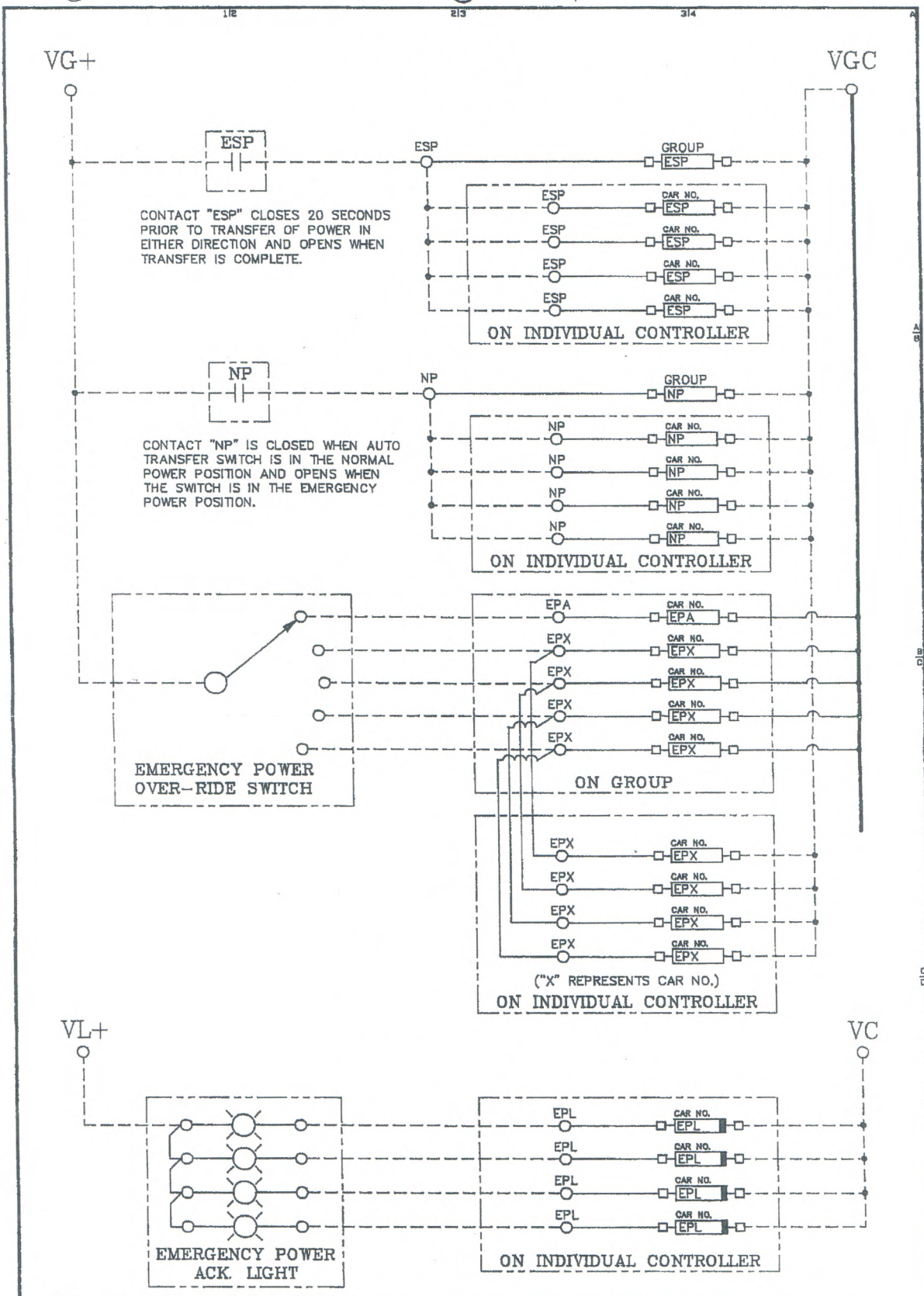

EMERGENCY POWER CIRCUITRY

COMPUTERIZED ELEVATOR CONTROL CORP.		DATE	RECORD CHANGES
636 11TH AVENUE NEW YORK, NEW YORK 10036 TEL (212) 397-0606		10-26-1989	REVISED
BUILDING: TEXAS AMERICAN BANK			
LOCATION: AMARILLO, TX			
CONTRACTOR: ELEVATOR TECHNOLOGY			
CAR NO. 1-4	DATE: 11-09-89		
DRAWING NO. MS600-1	JOB NO. 1730		

TO CONTROLLER

NOTE: * FGL IF REAR OPERATOR

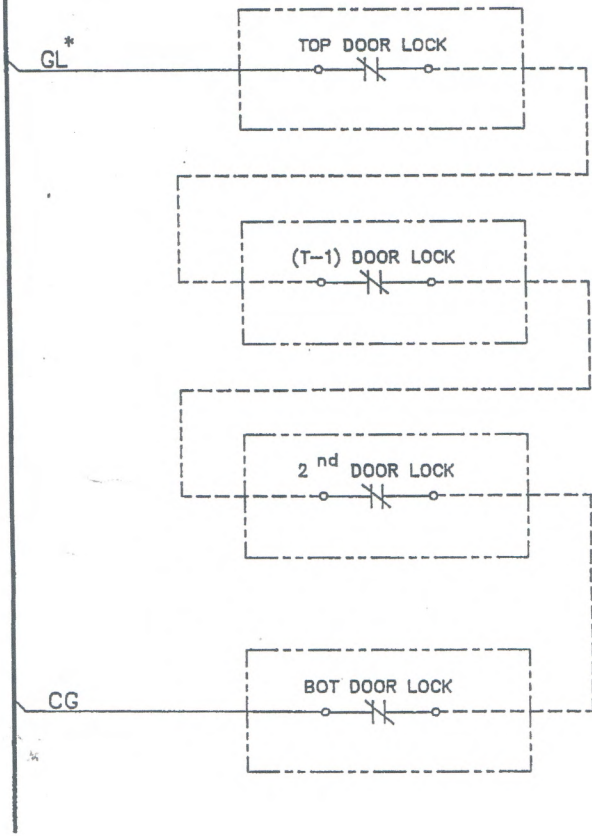

A
B
C
D
E

LOCKS AND LANTERNS WITHOUT ACCESS

NF

COMPUTERIZED ELEVATOR CONTROL CORP. 635 11TH AVENUE NEW YORK, NEW YORK 10036 TEL. (212) 397-0606	DATE	RECORD CHANGES
BUILDING: TEXAS AMERICAN BANK		
LOCATION: AMARILLO, TX		
CONTRACTOR: ELEVATOR TECHNOLOGY		
CAR NO. 1-9	DATE: 10-16-89	
DRAWING NO. WD252-2	JOB NO. 1130	

TO CAR CONTROLLER

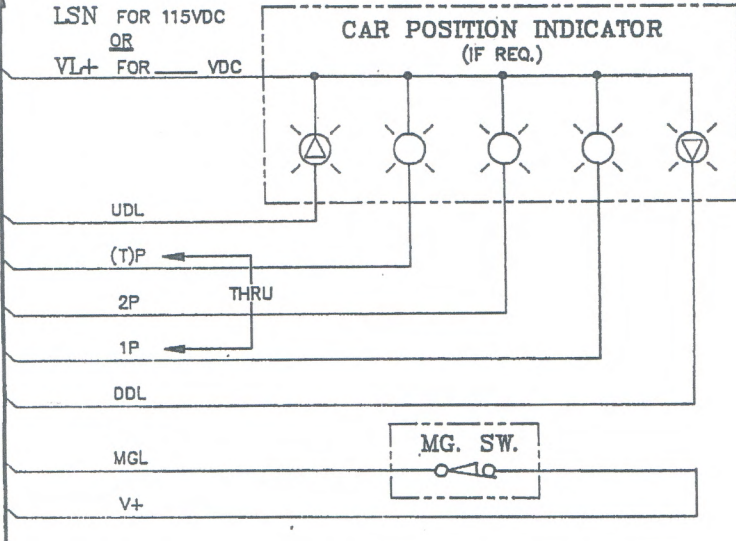

TO GROUP CONTROLLER

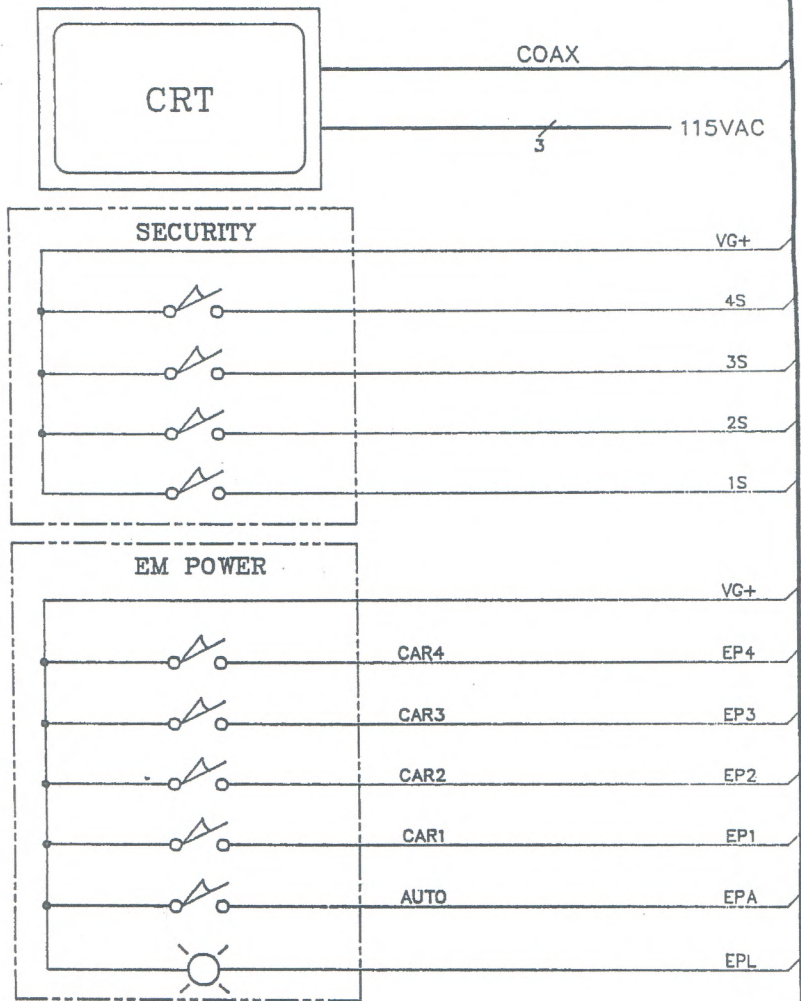

LOBBY STATION WIRING DIAGRAM

COMPUTERIZED ELEVATOR CONTROL CORP.		DATE	RECORD CHANGES
636 11TH AVENUE NEW YORK, NEW YORK 10036 TEL. (212) 397-0606			
BUILDING: TEXAS AMERICAN BANK			
LOCATION: AMARILLO, TX			
CONTRACTOR: ELEVATOR TECHNOLOGY			
CAR NO. 1-4	DATE: 10-16-89		
DRAWING NO. WD262-2	JOB NO. 130		

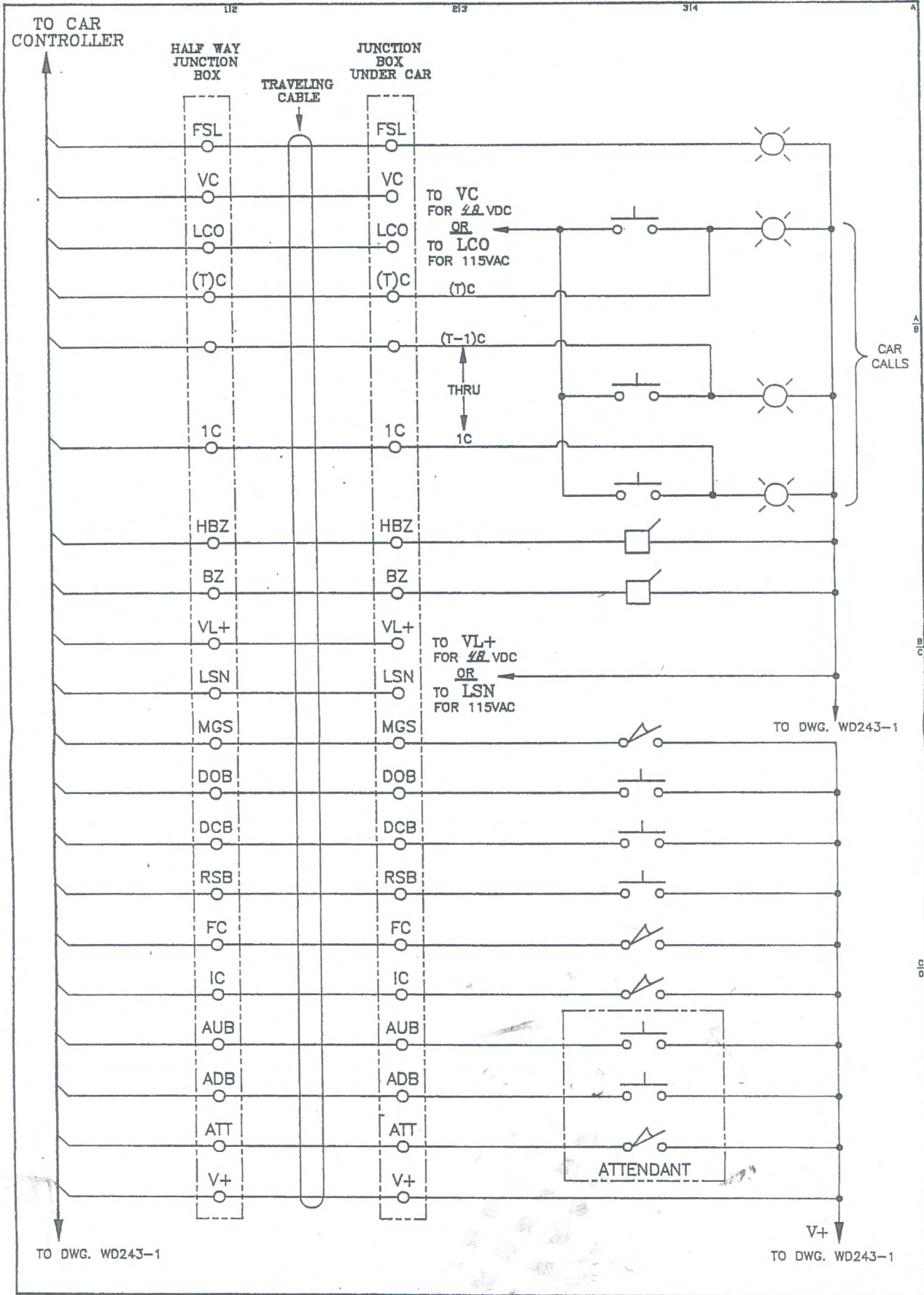

CAR STATION WIRING DIAGRAM

COMPUTERIZED ELEVATOR CONTROL CORP.		DATE	RECORD CHANGES
636 11TH AVENUE NEW YORK, NEW YORK 10036 TEL. (212) 397-0606			
BUILDING: TEXAS AMERICAN BANK			
LOCATION: AMARILLO, TEXAS			
CONTRACTOR: ELEVATOR TECHNOLOGY			
CAR NO. 1-4	DATE: 10-16-87		
DRAWING NO. WD242-1	JOB NO. 1730		